

Study in Taiwan,  
Be Excellent in NDHU

# Handbook

**For 2023 Spring Semester**

Office of International Affairs

National Dong Hwa University, Taiwan

---



# Welcome!

Please check the following lists to help you settle in and prepare for the future life in National Dong Hwa University.

I. Important Dates .....	4
II. Office of International Affairs .....	5
Important Faculties On Campus .....	5
Emergency Phone Number In Taiwan .....	5
Major Medical Hospitals Near Hualien City & NDHU .....	5
III. Before Arriving In Taiwan .....	6
A. Resident Visa Application .....	6
B. Flow Chart For Resident Visa Application.....	7
C. Key Points.....	7
D. Degree Verification.....	8
IV. Pre-Departure Check List.....	9
V. Volunteer, Flight & Dormitory .....	10
A. Volunteer Program .....	10
B. Reply Your Flight Information.....	10
C. Dormitory.....	10
VI. Transportation To NDHU .....	12
A. Taoyuan International Airport To Taipei Train Station.....	13
B. Taipei Train Station To Hualien Train Station .....	14
C. Hualien Train Station To NDHU Campus .....	14
D. OIA Int'l Shuttle Bus (Free for New Students).....	15
VII. Registration Guidelines & Procedure .....	16
A. Required Registration Documents.....	17
B. Online Registration .....	17
C. e-Portfolio .....	17
D. Payment Sheet.....	17

E. Tuition And Accommodation Fee .....	18
F. Notice .....	21
VIII. Alien Resident Certificate (ARC) Application .....	22
A. Documents Required .....	25
B. ARC Extension .....	25
C. Contact Window .....	26
IX. Arrangement for Health Insurance .....	27
A. Medical Insurance (Before join “National Health Insurance”) .....	27
B. Apply For Compensation .....	29
C. Students’ Safety Insurance Program .....	30
D. National Health Insurance (aka. N.H.I.) .....	30
E. Health Center .....	32
F. Psychology Counseling Center .....	32
G. Student Health Examination.....	32
X. NDHU E-mail & Wireless Internet Access .....	34
A. NDHU E-mail Account .....	34
B. How To Sign In Personal E-mail Account .....	34
C. Wireless Internet Access.....	35
XI. Course Selection .....	36
A. Important Reminders for the Course Registration Process .....	36
B. Required General Education Course For Undergraduate Students .....	37
C. Interdisciplinary Autonomous Learning Certification.....	37
D. Academic Research Ethics Education Course.....	37
XII. Open A Bank Account In Taiwan.....	38
A. Chunghwa Post Company (aka. Post Office) .....	38
B. Taiwan Business Bank: On-Campus & ATM.....	38
XIII. Work Permit.....	39
A. Required Documents .....	39

B. Notes.....	40
C. Common rejected cases.....	40
XIV. Academic Integrity & Plagiarism.....	41
XV. NDHU Complaint Processing Rules.....	42
XVI. Scholarship.....	43
A. Application Eligibility .....	43
B. Quota and Type .....	43
C. Awarded Students Must Comply With The Regulations & Duties .....	44
D. TOCFL Placement Test .....	48
XVII. International Student Identity Card .....	49
Required Documents .....	49
XVIII. NDHU Campus Map.....	50

# I. Important Dates

Date (mm/dd)	Event
1/6	[ONLINE] New International Student Entry Orientation @14:00-16:00 (GMT+8) > <a href="https://meet.google.com/frk-xsdr-koo">https://meet.google.com/frk-xsdr-koo</a>
1/20-1/30	<b>Holiday</b> Chinese Lunar New Year
1/31-2/12	<b>Holiday</b> Winter Vacation
2/6	Freshmen Course-Selecting (2/6 12:30 ~ 2/8 12:30)
2/8-2/9	Dormitory Opening for Spring Semester freshmen
2/10	Offline Orientation (morning) / Registration (afternoon)
2/13	<b>Classes Begin</b> Courses Drop Online (2/13 12:30 ~ 2/14 12:30)
2/14	Courses Add / Drop Online (2/14 12:30 ~ 2/21 12:30) <b>Tuition Payment Deadline</b>
2/27-2/28	<b>Holiday</b> 228 Peace Memorial Day
<b>TBD</b>	<b>International Student Health Examination by Health Center</b>
3/24	Tuition Refund Calculation Base Date for Suspension or Termination (1/3 Semester)
4/3-4/5	<b>Holiday</b> Spring Break
4/10-4/14	<b>Midterm Week</b>
4/17	Course Withdrawal (4/17 – 5/5)
5/5	Tuition Refund Calculation Base Date for Suspension or Termination (2/3 Semester)
5/22	Course Preliminary Selecting for Next Semester (5/22 12:30 ~ 5/30 12:30)
6/5-6/9	<b>Semester Evaluation Week</b>
6/16	<b>Classes end</b>
6/19	Winter Vacation Begins
6/20	Dormitory Closing (12:00 noon)
6/22-6/23	<b>Holiday</b> Dragon Boat Festival

Refer to NDHU Calendar: <https://sys.ndhu.edu.tw/AA/calendar/>

## II. Office of International Affairs

Office of International Affairs (OIA) is located at Room 601, 6F in Administration Building. Should you need information, welcome to come to OIA who would like to assist.

### Important Faculties on Campus

#### Office of International Affairs

International Scholar and Student Affairs Division (ISSA)	03-890-5116~5119 <a href="mailto:issa@gms.ndhu.edu.tw">issa@gms.ndhu.edu.tw</a>	Admin. Building 6F Room 601
International Recruitment and Admissions Division (IRA)	03-890-5112~5114 <a href="mailto:admission@gms.ndhu.edu.tw">admission@gms.ndhu.edu.tw</a>	Admin. Building 6F Room 601
International Academic Cooperation and Exchange Division (ICE)	03-863-5106~5109 <a href="mailto:ice@gms.ndhu.edu.tw">ice@gms.ndhu.edu.tw</a>	Admin. Building 6F Room 601
Division of Registry, Office of Academic Affairs	03-890-6112~6117 <a href="mailto:ying26@gms.ndhu.edu.tw">ying26@gms.ndhu.edu.tw</a>	Admin. Building 4F Room 401
Student Living Service Division, Office of Student Affairs (Dormitory)	03-890-6212, 03-890-6217 <a href="mailto:nacy4631@gms.ndhu.edu.tw">nacy4631@gms.ndhu.edu.tw</a> <a href="mailto:free22011@gms.ndhu.edu.tw">free22011@gms.ndhu.edu.tw</a>	Admin. Building 2F Room 208
Library	03-890-6838, 03-890-6839 <a href="mailto:library@gms.ndhu.edu.tw">library@gms.ndhu.edu.tw</a>	Library 1F Information Desk
Chinese Language Center	03-863-5238 <a href="mailto:clcndhu@gms.ndhu.edu.tw">clcndhu@gms.ndhu.edu.tw</a>	D204, College of Humanities and Social Sciences III
On-Campus Police	03-890-6119	
24-Hour On Campus Emergency Call	03-890-6995 0937-295-995	

### Emergency Phone Number in Taiwan

Police	110
Fire Department	119
Ambulance	119

### Major Medical Hospitals near Hualien City & NDHU

Mennonite Christian Hospital	03-824-1234
Tzu Chi General Hospital	03-856-1825
Hualien Hospital	03-835-8141
Zhi-Xue Clinic	03-866-1197

## III. Before Arriving in Taiwan

### A. Resident Visa Application

To apply for a Resident Visa before you arrive Taiwan. Resident Visa holders are required to apply for the Alien Resident Certificate (ARC) and Re-entry Permit at National Immigration Agency, R.O.C. (Taiwan) within 15 days after arrival.

ARC is one of the necessary documents if you study in Taiwan. Students come from visa free country that also need to apply for Resident Visa. (**According to the following the Regulation in Taiwan: International Students Undertaking Studies in Taiwan**)

Bureau of Consular Affairs, Ministry of Foreign Affairs, Republic of China (Taiwan):

<https://www.boca.gov.tw/mp-2.html>

#### Required Documents for Resident Visa Application

1. Visa online application: <https://www.boca.gov.tw/cp-166-283-c4da3-2.html>
2. Two 2-inch photos taken in the last six months (paste on application form)
3. Original and photocopy of passport (with blank visa pages and at least six months' validity): *The passport must be valid for at least 6 months and there are blank pages left in it. One photocopy of the passport bio-page including the holder's picture is required.*
4. [Health Certificate for Residence Application](#) from an accredited hospital: *You must complete the Health Certificate for Residence Application within three months before your departure. Earlier ones will not be accepted. For information on specific health certificate requirement please go to the website of Centers for Disease Control in Taiwan: <https://www.cdc.gov.tw/En>*  
*(Instruction: CDC Website> Diseases & Conditions > Foreigners' Health)*
5. Original and photocopy of NDHU's Letter of Admission
6. Original and one photocopy of highest education diploma and transcripts in English or Chinese version.
7. Original and one photocopy of proof of financial support
8. Other supporting documents

## B. Flow Chart for Resident Visa Application

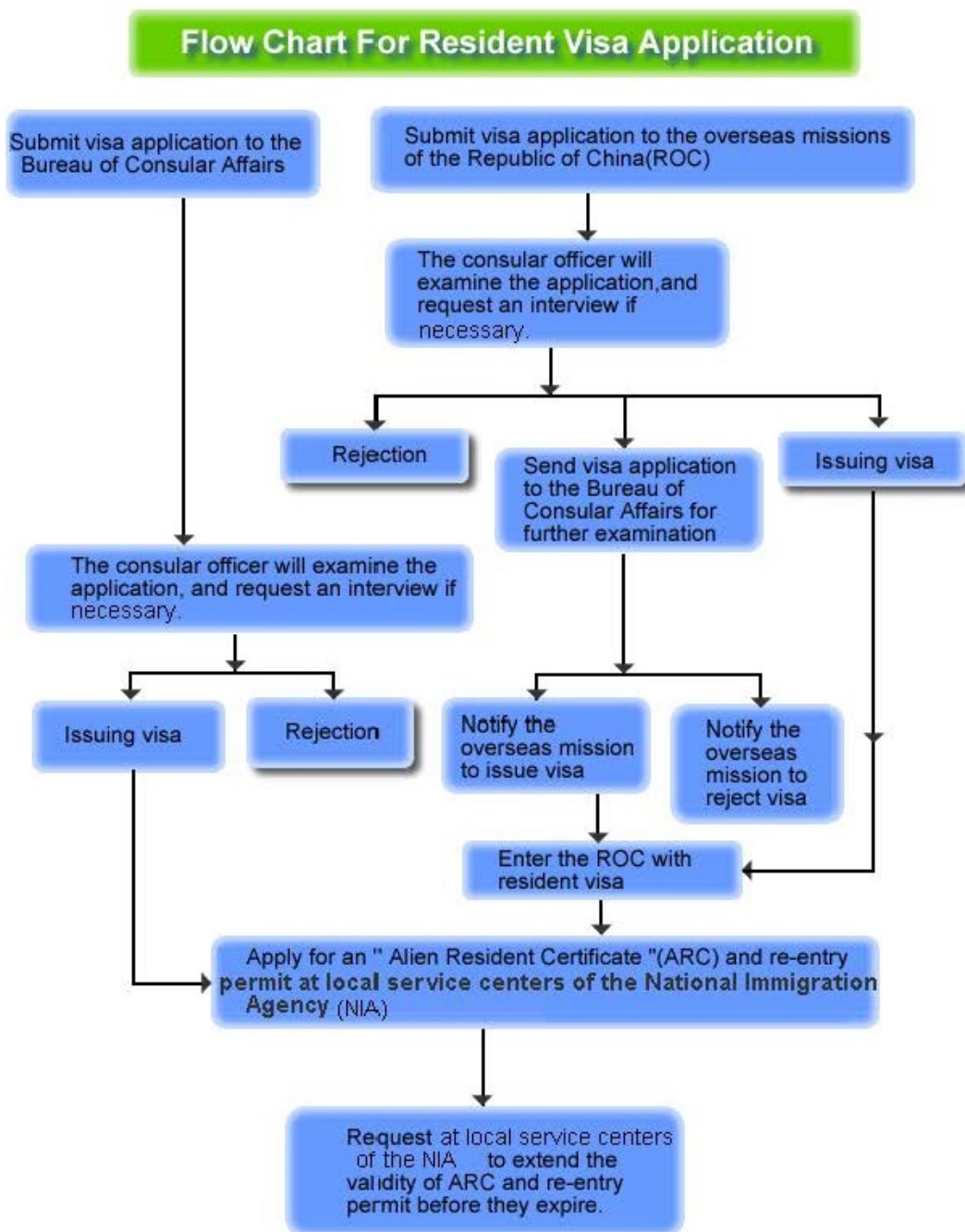

<https://www.boca.gov.tw/np-150-2.html>

## C. Key Points

**International students can only change to a Resident Visa from a Visitor Visa if the purpose of the Visitor Visa is "Studying in Taiwan".** If your VISA has a purpose other than this (including Visa free passports), you will be required to change it by applying a new Visa in another country, or extension to pursue their degree.



Foreigners who enter Taiwan with a Visitor Visa for the purpose of pursuing studies must make the necessary visa change into a Resident Visa at a Bureau of Consular Affairs, Ministry of Foreign Affairs before the Visitor Visa expiration date.

#### **D. Degree Verification**

You are required to submit the authenticated diploma and transcript during NDHU's Registration Day. You should have **previous degree of foreign diploma (or graduation certificate) and transcripts for all semesters verified by Taiwan embassy (or representative office) in the country of the institutions before the Registration Day.** Please verify the original documents and the translation in Chinese or English before you arrive in Taiwan.

**Please note you have to submit all the authenticated documents and make the full-payment to complete the registration procedure on Registration Day in order to get student ID card and student status certificate. Usually, the verification (authentication) procedures consume a lot of time (more than 2 months), please start the process as soon as possible.**

## IV. Pre-Departure Check List

	<p>Check your passport is valid and not to be expired. Make sure the name on your passport is correct and matches your registration documents.</p>
	<p>Refer to <b>Offline Registration Procedure</b>:</p> <p><a href="https://oia.ndhu.edu.tw/intl-student/intl-registration-guideline">https://oia.ndhu.edu.tw/intl-student/intl-registration-guideline</a></p> <div style="border: 1px solid black; padding: 5px;"> <p>► <b>After Arrival in Taiwan</b></p> <p><b>Offline Registration Procedure</b></p> <p>You should print out the following documents and organize the document order before offline registration day.</p> <ul style="list-style-type: none"> <li>◦ <a href="#">Procedure of Registration</a> ►►► Coming soon</li> <li>◦ <a href="#">Registration Guideline for New International Students</a> ►►► Please order your documents as this file.</li> <li>◦ <a href="#">Overseas Chinese and International Students Personal Information</a></li> <li>◦ <a href="#">Information for International Students at National Dong Hwa University (printed for 2 sets)</a></li> </ul> </div> <p>Read the <b>Procedure of Registration</b> and download the documents above.</p> <ol style="list-style-type: none"> <li>1. <b>ONE 2-inch photo taken within the last six months</b> Write down the student ID No., Name and Dept. on the backside of photo.</li> <li>2. <b>Original and Copy of Authenticated Diploma</b> Copy should be written down the student ID No., Name and Dept. at the upper right side.</li> <li>3. <b>Original and Copy of Authenticated Transcript of All Semesters</b> Copy should be written down the student ID No., Name and Dept. at the upper right side.</li> <li>4. Fill out the <b>Registration Guideline for New International Students</b> (only personal info) and <b>Overseas and International Students Personal Information form</b></li> <li>5. <b>Admission Letter</b> For Taiwan Scholarship or Non-NDHU Scholarship Recipient, please submit the certificate</li> <li>6. Prepare <b>cash of NT\$ 3,000 for medical insurance</b> (only overseas international students) <b>or</b> cash of NT\$ 4,956 for National Health Insurance (who has already got NHI card in Taiwan)</li> </ol>
	<p><b>Alien Resident Certificate (ARC) is required documents after arriving in Taiwan. (page 22)</b> Photo format must to be followed the requirement as immigration agency website. <a href="https://coa.immigration.gov.tw/coa-frontend/student/entry/foreign-student">https://coa.immigration.gov.tw/coa-frontend/student/entry/foreign-student</a></p>
	<p>Make your travel arrangement. (ex. flight ticket, luggage, currency exchange and so on)</p>
	<p>Bring your any vaccination certificates (optional)</p>
	<p>Prescribed medicine with doctor's prescription and medical history (optional)</p>
	<p>Arrange to bring a traveler's check <b>or</b> New Taiwanese Dollar (NTD) for payment of school and living expense for first 2 months.</p>

# V. Volunteer, Flight & Dormitory

## A. Volunteer Program

OIA will assign you an NDHU student volunteers. The student volunteers can help you with both academic and practical matters at school, such as the online course selection system procedures, offline registration and so on. Please feel free to ask them for solving any problems without hesitation.

## B. Reply Your Flight Information

OIA doesn't provide the pick-up service from the airport. However, **we offer shuttle bus from Hualien Train Station to NDHU campus** and your volunteers will assist you. The contact information of both volunteers and international students will be mutually given, in order to the convenience of reaching.

To confirm flight info and arrival time, please fill in the Google form after getting VISA and flight ticket.

Link: <https://forms.gle/5v28V4naff5AXnLF6>

If you have visa/flight issue or other problems, please write an email to inform [issa@gms.ndhu.edu.tw](mailto:issa@gms.ndhu.edu.tw).

## C. Dormitory

The dormitory for Spring Semester has already reserved for international new students who have already reserved the room in Google form in advance. OIA and Student Living Division will arrange for you.

If you have specific condition (ex. physical or mental condition) to ask for a single room or double room, please provide the relevant documents and send to [issa@gms.ndhu.edu.tw](mailto:issa@gms.ndhu.edu.tw). We will note your request and report to Student Living Division. But, they cannot guarantee to keep the rooms for you because it depends on room vacancy.

Check the result and get the room number:

<https://sys.ndhu.edu.tw/SA/Dorm/login.aspx>

If you want to apply for changing dormitory, please contact Student Living Division on 2F in Administration Building **after semester starts**.

Dormitory will be open and available for new students on Feb 8-9, 2023.

- ▶ Please be advised NDHU **won't provide the accommodation** before the date above.
- ▶ The dormitory deposit is NT\$ 2,000.

Dormitory Information from Student Living Division in Office of Student Affairs:

<https://rb005.ndhu.edu.tw/p/412-1005-489.php>

The screenshot shows the website for the Student Affairs Office (學生事務處). The main navigation menu includes: 生活輔導組, 大學部在校生(請點擊圖片進入), 首頁, 最新消息, 本組介紹, 校內宿舍資訊, 校外買居資訊, 獎學金, 助學措施, 獎助生(計畫類學習型助理)團保專區, and 遺失物查詢暨處理. The '校內宿舍資訊' (On-campus dormitory information) section is highlighted with a red box and contains a sub-menu with the following items: 大學部新生和轉學生, 大學部在校生, 碩博士生, 宿舍相關法規, 宿舍住宿須知, 宿舍連絡電話, and 線上申請. Below the menu, there is a large image of a dormitory building with the caption '操雲一、二莊(男、女舍)'. At the bottom, there are four smaller images of different dormitory buildings.

If you have questions about dormitory, please directly contact below.

【Contact Info】

Mrs. Chen: 03-890-6212, [yishoue@gms.ndhu.edu.tw](mailto:yishoue@gms.ndhu.edu.tw)

Mrs. Chung: 03-8890-6217, [free22011@mail.ndhu.edu.tw](mailto:free22011@mail.ndhu.edu.tw)

## VI. Transportation to NDHU

After arriving in Taiwan....



Schedule	Duration
Currency Exchange / Apply Taiwanese phone number	30 min
From Taoyuan International Airport to Taipei Main Station	Bus: 1-1.5 hrs Taoyuan Metro: 40 min
From Taipei Main Station to Hualien Main Station	Express: 2-2.5 hrs
From Hualien Main Station to NDHU main campus	Taxi/Bus: 30-45 min
Arrive to NDHU dormitory	10 min

Taoyuan International Airport: <https://www.taoyuan-airport.com/english>

## A. Taoyuan International Airport to Taipei Main Station

After arriving at Taoyuan International Airport, you may choose to take a bus, taxi or Taoyuan Metro to Taipei Main Station.

### 1. Buses

Ticket counters are located in the Arrival Passenger Reception areas of both Terminal 1 and Terminal 2.

Bus Platform at Terminal 1: Bus pick-up zone at B1 Arrivals

Bus Platform at Terminal 2: Bus pick-up zone at the northeast arcade of the Arrivals lobby on 1st floor

One-way fare varies from NT\$ 110 to NT\$ 140 per adult. (From Taoyuan airport to Taipei Main Station)

Taoyuan International Airport Website (Taipei buses):

[https://www.taoyuan-airport.com/main\\_en/buses.aspx?uid=517&pid=420](https://www.taoyuan-airport.com/main_en/buses.aspx?uid=517&pid=420)

### 2. Taxi

Taxis operating by shifts are located at the west side of the Terminal 1's and Terminal 2's Arrivals Lobby at the Taiwan Taoyuan International Airport. All taxis and drivers must pass a strict evaluation process by the Aviation Police Office before being allowed to service airport travelers. The comprehensive management protocol ensures safety for all travelers.

#### Fare

Taxi fare is based on the meter plus a 15% surcharge (highway tolls are not included). Airport taxis transport passengers are everywhere in Taiwan.

Operating hours: Airport taxis provide transportation 24-7 service.

#### Service number

Terminal 1 Taxi service center: +886-3-3982832

Terminal 2 Taxi service center: +886-3-3983599

Complaints: +886-3-3834499

Taoyuan International Airport Website (Taxi): [https://www.taoyuan-airport.com/main\\_en/docdetail.aspx?uid=520&pid=420&docid=176](https://www.taoyuan-airport.com/main_en/docdetail.aspx?uid=520&pid=420&docid=176)

### 3. Taoyuan Metro

Airport Station to Taipei Main Station: NT\$ 160

Taoyuan Airport MRT (Metro) Website: <https://www.tymetro.com.tw/tymetro-new/en/index.php>

## B. Taipei Main Station to Hualien Main Station

### One-way ticket

Departure Station: Taipei Station

Destination Station:

Hualien Station (16 km North of NDHU)

Shoufeng Station (4 km South of NDHU)

Zhixue Station (750 m from NDHU back gate, 2 km from NDHU front gate)

### Fare

Tze-Chiang Limited Express: NT\$ 440 (Taipei-Hualien)

Taiwan Railways Administration website: [https://www.railway.gov.tw/tra-tip-web/tip?lang=EN\\_US](https://www.railway.gov.tw/tra-tip-web/tip?lang=EN_US)

APP: TRA E-booking

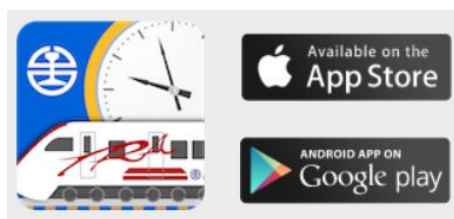

## C. Hualien Main Station to NDHU Campus

### 301 Shuttle Bus (Taroko Bus)

Bus stop is at the front exit of Hualien Main Station.

<https://www.taiwanbus.tw/eBUSPage/Query/QueryResult.aspx?rno=03010&rn=1606880571477>

### 1121, 1128 Shuttle Bus (Hualien Bus)

Bus stop is at the front exit of Hualien Main Station.

Website: [http://www.hualienbus.com.tw/bus/ticket\\_info.php](http://www.hualienbus.com.tw/bus/ticket_info.php)

### Purchasing and Supply Section, Office of General Affairs

Timetables: <https://ga.ndhu.edu.tw/p/405-1006-150910,c17163.php?Lang=zh-tw>

### Taxi

Chung-Mei Taxi (中美計程車): 03-8234432, 03-8237011

Ming-Xin Taxi (名星汽車行): 0800-432-432

Guo-Fong Taxi (國風汽車行): 0800-097-097

### Fare

From Hualien Station to NDHU is around NT\$300-350 (day time) and NT\$400-450 (night time).

The detailed info of taxi fare:

<https://ga.ndhu.edu.tw/var/file/6/1006/img/2120/748171445.pdf>

### D. OIA Int'l Shuttle Bus (Free for New Students)

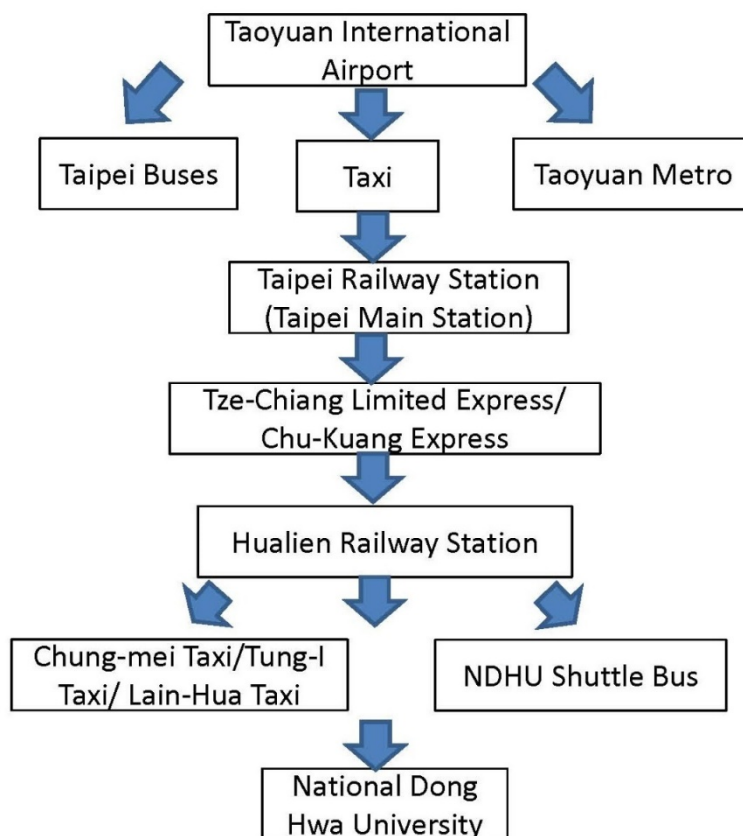



## VII. Registration Guidelines & Procedure

1. To check required documents, arrange them in the order of Registration Guideline for New International Students and submit them on the registration day.

**Registration Guideline for New International Students and Procedure of Registration:** <https://oia.ndhu.edu.tw/intl-student/intl-registration-guideline>

2. Complete **online registration system**

Upload your ID photo and your personal info, in order to make your Student ID Card. Link: <https://sys.ndhu.edu.tw/AA/REG/register/>

**account: student ID number**

**password: YYYY.MM.DD (your birthday)**

3. Complete **e-Portfolio system**

You also could download Student Status Certificate after finishing offline registration. Student Status Certificate is valid only for a semester. Therefore, you have to download it per semester.

Link: [https://sys.ndhu.edu.tw/CTE/Ed\\_StudP\\_WebSite/Login.aspx](https://sys.ndhu.edu.tw/CTE/Ed_StudP_WebSite/Login.aspx)

**account: student ID number**

**password: YYYY.MM.DD (your birthday)**

4. Complete **Online Course Selection System**

**account: student ID number**

**password: student ID number+0**

(Ex. if your student id is 410112345, your password would be 4101123450.)

5. Log in your **school Gmail**

**account: student ID number@gms.ndhu.edu.tw**

**password: YYYY.MM.DD (your birthday)**

## A. Required Registration Documents

Please see IV. Pre-Departure Check List. (page 10)

## B. Online Registration

Online Registration: <https://sys.ndhu.edu.tw/AA/REG/register/>

This system is aim to collect student's personal information and upload the photo for Registry Division, Office of Academic Affairs in order to make the Student ID Card. After completing the system, you are able to do the course selection. **Please note fill out the permanent address in your home country.**

**account: student ID number**

**password: YYYY.MM.DD (your birthday)**

## C. e-Portfolio

e-Portfolio: [http://sys.ndhu.edu.tw/CTE/Ed\\_StudP\\_WebSite/Login.aspx](http://sys.ndhu.edu.tw/CTE/Ed_StudP_WebSite/Login.aspx)

This system is aim to download the Student Status Certificate, check the score and see the medical check-up report, etc.

**account: student ID number**

**password: YYYY.MM.DD (your birthday)**

## D. Payment Sheet (as Proof of Accommodation for ARC)

The tuition, credit or miscellaneous fee will be exempted on the payment sheet according to the scholarship type. **Your student status will be valid after making the full-payment on registration day.** Thereafter, the student status Certificate will be issued to apply for the ARC, bank account, work permit, permanent telecom account for mobile phone and so on. You can download the payment sheet **after paying the tuition.**

Payment sheet: <https://school.bot.com.tw/newTwbank/StudentLogin.aspx>

Printed Instructions:

[https://rb033.ndhu.edu.tw/var/file/0/1000/attach/66/pta\\_93437\\_5246261\\_06752.pdf](https://rb033.ndhu.edu.tw/var/file/0/1000/attach/66/pta_93437_5246261_06752.pdf)

**ID number: your student ID number +0**

**Student ID number: your student ID number**

**Birth date: (blank)**

各級公私立高中職以上學生(學校位於台北市及高雄市除外), 如欲辦理就學貸款。  
請至台灣銀行就學貸款入口網線上申請, 網址: <https://sloan.bot.com.tw/>

國立東華大學 106 學年度 第一學期 繳費收據		1133286111008304 008304 第一聯: 繳款人收執聯	
繳款人	學號	部別	系所/科別
座號	年級	學生班 院別	管理科學與財金國際學士學位學程 班別
收入科目		金額	
01. 學費	33,580	02. 雜費	14,620
03. 大學部學分費	0	04. 中等教程學分費	0
05. 小教學學分費	0	06. 網路通訊費	300
07. 住宿費	9,500	08. 住宿保證金	2,000
09. 宿舍網路使用費	250	10. 鑰匙使用費	0
11. 團保費	234	12. 個別指導費	0
13. 鍵鑰維護費	0	14. 僑外生健保費	0
15. 延繳學分費	0	16. 交換生隨費	0
合計新臺幣 陸萬零仟肆佰捌拾肆元整 (NT\$ 60,484)			

備註:  
一、臺灣銀行各分行、郵局、信用卡、ATM轉帳、統一及全家等均可繳納。  
二、就學貸款可貸金額: 每本繳費學可貸項目加書籍費 3 仟元, 本校住宿費最高 1 0 7 0 0 元。  
三、已辦安休、退學及畢業生無需繳費。  
四、出納組聯絡電話 0 3 - 8 6 3 2 3 6 4

1. 本繳費單支援銀聯卡網路繳費, 請至 <https://school.bot.com.tw/> 點選「海外銀聯卡專區」進行繳費。  
2. 透過台銀網路銀行繳納免手續費, 持他行金融卡用台銀網路ATM點選「轉繳費稅卡款」, 公立國中小手續費6元, 其他學校10元。  
3. 信用卡網路繳費, 請至 <https://school.bot.com.tw/> 點選「信用卡繳費」即可繳費並列印收據(信用卡繳學雜費不收手續費, 分期付款除外)  
收款銀行及經辦人: 主辦出納: 張春梅 主辦主計: 鳳麗華 機關長官: 趙滿捷

### Tuition of Master and PHD

Credit fee: One credit for NT\$ 3,060

Miscellaneous: NT\$ 25,800

### Tuition of Bachelor

Tuition: NT\$ 21,680

Miscellaneous: NT\$ 33,900

Dormitory fee: <https://rb004.ndhu.edu.tw/p/404-1004-175369-1.php?Lang=zh-tw>

Dormitory Deposit: NT\$ 2,000

Dormitory Internet: NT\$ 250

Medical insurance: NT\$ 3,000 or National Health Insurance: NT\$ 4,956

Student group Insurance: NT\$ 340

Networking Infrastructure: NT\$ 300

Reference from NDHU Tuition Standard from Registry Division, Office of Academic Affairs: <https://aa.ndhu.edu.tw/p/404-1004-175369-1.php?Lang=zh-tw>

## E. Tuition and Accommodation Fee

Tuition fee for department: <https://aa.ndhu.edu.tw/p/404-1004-175369-1.php?Lang=zh-tw>

The accommodation fees for each student dormitory are as follows:

- The accommodation fee for Dormitory 1, Dormitory 6, and Dormitory 7 is **NT\$9500/semester**.
- The accommodation fee for Dormitory 2, Dormitory 3, and Dormitory 4 is **NT\$7500/semester**.
- Dormitory 5 accommodation fee is **NT\$10700/semester**.

## National Dong Hwa University Dormitory Fees List

### Fees List for Every Semester Each Hall

Hall	Boarder	Period	Accommodation Fees/NTD/per person	Electricity Fees	Deposits /NTD/per person	Fees Advance for Boiler Use
Dormitory I (single room)	Graduate Student	Semester ( 4.5mont hs )	\$ 9,500NT ( Including \$500 Basic Electricity Fees )	Actual charges based on air-conditioning and general use of meter power calculation	\$ 2,000NT	—
New Dormitory Block A (double room)	Graduate & Undergraduate Student (Male)	Semester ( 4.5mont hs )	\$ 10,700NT ( Including \$500 Basic Electricity Fees )	Actual charges based on air-conditioning and general use of meter power calculation	\$ 2,000NT	—
New Dormitory Block B (double room)	Graduate & Undergraduate Student (Female)	Semester ( 4.5mont hs )	\$ 10,700NT ( Including \$500 Basic Electricity Fees )	Actual charges based on air-conditioning and general use of meter power calculation	\$ 2,000NT	—
Dormitory II (four suites)	Undergraduate Student (Female)	Semester ( 4.5mont hs )	\$ 7,500NT ( Including \$500 Basic Electricity Fees )	Actual charges based on general use of meter power calculation	\$ 2,000NT	—
Dormitory III (four suites)	Undergraduate Student (Female)	Semester ( 4.5mont hs )	\$ 7,500NT ( Including \$500 Basic Electricity Fees )	Actual charges based on general use of meter power calculation	\$ 2,000NT	\$ 1,000NT
Dormitory III (four suites)	Undergraduate Student (Male)	Semester ( 4.5mont hs )	\$ 7,500NT ( Including \$500 Basic Electricity Fees )	Actual charges based on general use of meter power calculation	\$ 2,000NT	\$ 1,000NT

Dormitory IV (four suites)	Undergraduate Student (Male)	Semester (4.5 months)	\$ 7,500NT (Including \$500 Basic Electricity Fees)	Actual charges based on general use of meter power calculation	\$ 2,000NT	\$ 1,000NT
New Dormitory Block C, D (four suites)	Undergraduate Student (Female)	Semester (4.5 months)	\$ 9,500NT (Including \$500 Basic Electricity Fees)	Actual charges based on general use of meter power calculation	\$ 2,000NT	—
New Dormitory Block E, F (four suites)	Undergraduate Student (Male)	Semester (4.5 months)	\$ 9,500NT (Including \$500 Basic Electricity Fees)	Actual charges based on general use of meter power calculation	\$ 2,000NT	—

**Statement:**

1. Fees related to accommodation applying (including electricity fees, deposits, and fees advance for boiler use) should be paid at the same time together with the accommodation fees, not sub-pay.
2. Others electric equipment \$500 (such as: electricity for small refrigerator use), deal according to “National Dong Hwa University dormitory electrical use rules”.
3. Students should comply with the provisions of the school dormitory, management practices and conventions of life. Damage to public property, if any, is willing to pay the full price compensation, and willing to bear all of its responsibility to conduct safety during accommodation period.
4. When entering hostel, please complete public property inventory and check with the state survey in dormitory on personal own according to inventory of dormitory property within provisions days; when applying for dormitory check out, you can only check out after property inventory cum clean inspection is passed.



Estimated Expenses for International Student at NDHU:

<https://oia.ndhu.edu.tw/intl-student/tuition-accommodation-fee>

<b>Estimated Expenses for Self-supporting Student at NDHU (Master &amp; Ph.D)</b>		
	NTD/semester	USD/semester
<b>PERSONAL EXPENSES</b>		
On-campus accommodation	\$ 10,000	\$ 333
Living Costs	\$ 36,000	\$ 1,200
<b>Total Personal Expenses</b>	<b>\$ 46,000</b>	<b>\$ 1,533</b>
<b>TUITION AND FEES</b>		
Miscellaneous Fees (including student insurance fee, computer fee, and etc..)	\$ 25,000	\$ 833
Credit Fee	\$ 3,060	\$ 102
<b>Total Tuition and Fees</b>	<b>25,000+(NT\$3,060* credits)</b>	<b>833+(US\$102* credits)</b>
<b>Total Personal expenses plus Tuition &amp; Fees</b>	<b>(25,000+NT\$3,060* credits)+46,000</b>	<b>(833+US\$102*credits)+ 1,533</b>

<b>Estimated Expenses for Self-supporting Student at NDHU (Bachelor)</b>		
	NTD/semester	USD/semester
<b>PERSONAL EXPENSES</b>		
On-campus accommodation	\$ 10,000	\$ 333
Living Costs	\$ 36,000	\$ 1,200
<b>Total Personal Expenses</b>	<b>\$ 46,000</b>	<b>\$ 1,533</b>
<b>TUITION AND FEES</b>		
Tuition & Miscellaneous Fees (including student insurance fee, computer fee, and etc..)	\$ 55,000	\$ 1,833
<b>Total Tuition and Fees</b>	<b>\$ 55,000</b>	<b>\$ 1,833</b>
<b>Total Personal expenses plus Tuition &amp; Fees</b>	<b>\$ 101,000</b>	<b>\$ 3,367</b>

\*\* The above numbers are estimates and will be affected by choice of life style, personal needs, and exchange rates.

Exchange Rate: 1USD=30NTD

## F. Notice

**The registration process is considered completed when all required fees have been paid, all the necessary documents have been submitted and the online registration have been finished.** If the deadline is over and students haven't finished the above steps, students will be considered unregistered.

## VIII. Alien Resident Certificate (ARC) Application

Resident Visa holders are required to apply for ARC **within 15 days** after their arrival. You may stay in Taiwan as long as the ARC remains valid. The process of making a new ARC takes at least two weeks, if you submit required documents successfully.

### ARC Online Application System:

<https://coa.immigration.gov.tw/coa-frontend/student/entry?lang=en>

### First-time ARC application instruction manual (Application with a resident visa)

<https://www.youtube.com/watch?v=G3tq03f9Qnc&t=87s>

**August 1st**

Online application system to be launched on 2021/8/1

**STUDENTS ONLINE APPLICATION SYSTEM**

APPLICANTS : FORMAL ACADEMIC DEGREE STUDENTS

IF STUDENTS HAVE ANY QUESTIONS REGARDING THEIR ONLINE APPLICATION, PLEASE CALL THE SERVICE LINE OR ENQUIRE AT NIA SERVICE CENTERS.  
SERVICE LINE:  
FOR ONLINE OPERATION/SYSTEM PROBLEMS(CHINESE) 02-2796-7162  
FOR FOREIGNERS IN TAIWAN HOTLINE (AVAILABLE IN 7 LANGUAGES): 0800-024-111

內政部移民署 新住民發展基金 廣告

launched on  
August 1st  
2021

## Students Online Application System



### 1. Applicants:

formal academic degree  
students

### 2. Where to apply ?

<https://coa.immigration.gov.tw/coa-frontend/foreign-student/individual/login>



Please visit the NIA website :  
Home/application information/online application

### 3. Required documents:

Items	Photo (2x2 inches)	Passport	Resident Visa	Proof of Accommodation	ARC	Admission Permit or Certificate	Other Supporting Documents (Optional)
First-time ARC application (accepted by a school but not yet enrolled)	✓	✓	✓	✓		✓Certificate of Admission Permit	
First-time ARC application (enrolled)	✓	✓	✓	✓		✓Certificate of Enrollment or student ID	
ARC extension application	✓	✓			✓	✓Certificate of Enrollment /student ID with a valid registration stamp	
Change of ARC information application	✓	✓			✓		✓ex: renewal of passport, police statements or reports of lost ARC, lease or proof of dormitory payment



## 4. Application process:



The screenshot shows the 'ARC Application for Foreign Students and Overseas Chinese Students' online system. The header includes the National Immigration Agency (NIA) logo and the text '外國與外僑、大陸與港澳、無戶籍國民學生線上申辦系統'. The main content area is titled 'Application Details' and contains several sections:

- Upload Photo:** A placeholder for a photo with a 'Clear' button.
- Eligibility:** Foreign students and Overseas Chinese Students entering Taiwan for study.
- Program of Study:** Master's Degree.
- School:** A dropdown menu with the text 'Please select'.
- Status of Study:** A dropdown menu with the text 'Please select'.
- \*1. Admission Permit or Certificate:** A dropdown menu with the text '沒有選擇檔案' and a 'Clear' button.
- \*2. Passport:** A dropdown menu with the text '沒有選擇檔案' and a 'Clear' button.

To the right of the screenshot is a vertical list of five steps:

1. Prepare required documents
2. Create and activate an account
3. Log in to the account to fill in the application form and upload required documents
4. Pay after approval
5. Print out the Electronic ARC / Download the receipt and get the ARC IC Card at NIA service centers

## 5. Ask for help:

With regard to online operation/ system problems, please call Service Line : 02-2796-7162。

Foreigners in Taiwan Hotline (available in 7 languages) :  
Domestic : 0800-024-111 Overseas : 886-800-024-111

Office hours of NIA service centers : 08:00 a.m. -5:00 p.m.,  
Monday to Friday

## A. Documents Required

1. Application with passport photo which is taken within last six months  
(Photo format must be followed below proportion and requirements.)
2. Original and Photocopy of Passport and Resident Visa (including entry stamps)
3. Original and Photocopy of **Student Status Certificate** which new students will get it after completing the Registration Process.
4. Proof of Accommodation: Please download your tuition payment sheet on Taiwan Bank. Link: <https://school.bot.com.tw/newTwbank/StudentLogin.aspx>  
(Instruction see **Page 19**)
5. Original and Photocopy of Admission letter
6. NT\$ 1,000 per year

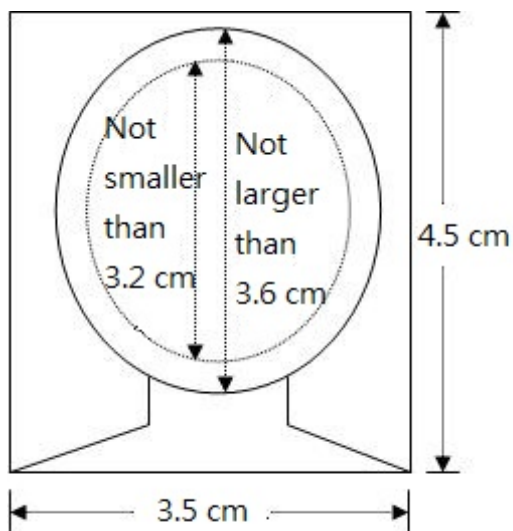

The photo should be colorful and was taken within 6 months. The portrait should be without hat, and the face and features should be clear. The background should be white.

### E-residence Permit (e-ARC) and Receipt Download

After the application is reviewed and approved by National Immigration Agency and then the payment is successfully done, foreign and overseas Chinese students who file the application will receive an e-mail automatically sent by the system informing that the e-residence permit(e-ARC) and receipt are ready for download.

By signing into the system, foreign and overseas Chinese students are able to download their e-residence permits (e-ARC) and receipts from "e-residence permit download" and "receipt download" in the "download section". After finishing offline registration, please upload certificate of student status to ARC system. If you have received the email to inform you to take IC card, please bring your e-ARC and receipt to the service station in exchange for the IC card as a residence permit.

## B. ARC Extension

Prepare for ARC extension **at least one month before it expires**. The procedure is as follows:

1. Make the full-payment of tuition and miscellaneous fees for the upcoming semester.

Submit below required documents to NIA online. link:

<https://coa.immigration.gov.tw/coa-frontend/student/entry?lang=en>

- Application with passport photo which is taken within last six months
  - Original and Photocopy of Passport and Resident Visa
  - Current ARC
  - Original and copy of student ID card and **student status certificate**  
NT\$ 1,000 per year
2. If failed to extend ARC before the next reentrance to Taiwan, you must apply for a Resident Visa again to enter as immigration regulation.

## Notices

If you overstay but are still enrolled, you must follow the Immigration rules to pay the fine (The worst situation is “you will be sent out of Taiwan”.) and the application fee for the ARC extension.

Overstay fine:

1-10 days: NTD\$2,000	61-90 days: NTD\$8,000
11-30 days: NTD\$4,000	over 91days: NTD\$10,000
31-60 days: NTD\$6,000	

## C. Contact Window

Hualien County Service Center  
National Immigration Agency  
5F, No.371, Zhongshan Rd.  
Hualien City, Hualien County 970  
Phone: 03-832-9700

Pingtung County Service Center  
National Immigration Agency  
No. 185, Zhili Rd.  
Pingtung City, Pingtung County 900  
Phone: 08-721-6665

## IX. Arrangement for Health Insurance

Medical expenses can be very expensive in Taiwan if you are not insured. Therefore, it is extremely important to understand the insurance policies and the health care system in Taiwan.

According to Article 22, Regulations Regarding International Students Undertaking Studies in Taiwan, Ministry of Education, **students must have medical insurance during study period in Taiwan.**

<http://edu.law.moe.gov.tw/EngLawContent.aspx?lan=E&id=288&KW=%E5%A4%96%E5%9C%8B%E5%AD%B8%E7%94%9F>

*When a new international student registers, they shall submit proof of being covered by a medical and injury insurance policy which is valid for at least six months from the date that they entered Taiwan. Current students shall present documentary proof that they have joined Taiwan's National Health Insurance Plan.*

*If the proof of insurance referred to in the previous paragraph was issued in a foreign country, it shall be authenticated by an overseas mission.*

### **A. Medical Insurance (Before join “National Health Insurance”)**

At the time of registration new international students shall present proof of a medical and injury insurance policy which is valid for at least 6 months from the date the student enters Taiwan. Current student shall present written proof that they have joined Taiwan's the National Health Insurance Plan. Upon enrollment, international students are required to submit proof of insurance covering their medical expenses during the six-month period after their arrival and before joining the “National Health Insurance (NHI)”. The private health certificate of foreign countries should be verified by Taiwan Oversea Representative Office.

**Students who cannot provide the proof of above insurance must purchase the required medical insurance through OIA.** The medical insurance is NT\$ 3,000 for 6 months.

**NOTE:** We suggest new students to use Taiwanese medical insurance. If there are any accidents or you are seeing doctors, you have to pay full amount by yourself first. But, you could apply for the refund from insurance company, please see the following regulation of the medical insurance:

## Cathay Life Insurance Group Foreign students health insurance

### Coverage

#### Outpatient/Emergency treatment benefit :

While this Policy is still effective, if the Insured suffers an illness or injury and receives (emergency) treatment at a hospital/clinic as an outpatient, the company will reimburse all medical expenses incurred. However, the payment of benefit shall not exceed the limit of 1000 NTD (per visit).

#### Daily hospital room benefit :

While this Policy is still effective, if the Insured suffers an illness or injury and receives treatment at a hospital as an inpatient, the company will reimburse the following expenses incurred.

1. Balance billing on hospital rooms .
2. Food, except for nutrients provided through tube feeding .
3. Nursing care fee excluding special nurse fee.

However, the payment of benefit shall not exceed the limit of 1000 NTD (per day).

#### Hospital miscellaneous benefit :

While this Policy is still effective, if the Insured suffers an illness or injury and receives treatment at a hospital as an inpatient, the company will reimburse the following expenses incurred.

1. Physician instructions medication.
2. Blood, except for blood transfusions deemed necessary by a doctor providing emergency care
3. Registration fee and cost of obtaining related certificates
4. Ambulance fee (from or between hospital).
5. Operation fee.
6. Operation room, post-operative recovery room, emergency room or the application of its equipment.
7. Materials fee.
8. Laboratory tests, electrocardiogram, basal metabolic rate check.
9. Rehabilitation therapy.
10. Anesthetics, oxygen, and its application.

11. Therapeutic radiology.
12. Hemodialysis.
13. Injection and its liquid medicine.
14. Laboratory examination.
15. Treatment.

However, the payment of benefit shall not exceed the limit of 120,000 NTD (per hospitalization).

#### **The provisions of the insured**

Insurer qualifications : Limited to foreign students(including Mainland China students and Overseas Chinese students).

Insured age limit : From 15 years old to 50 years old.

Insured's name shall be specified in the policy

Policy period/term : One year.

Premium mode : Yearly, Half yearly, Quarterly ,Monthly

#### **Note :**

1. The above information is for reference only. For details of the terms and conditions, please refer to the policy contract (Chinese version).
2. The terms and conditions of insurance policy (Chinese version) shall prevail if there is any inconsistency between the above information and the insurance policy.

## **B. How to apply for Compensation from insurance company**

1. Make sure the policy term.
2. See the doctor and make the full medical payment.
3. Apply for original "Medical Report (Doctor's note)" and "Receipt" from hospital or clinic.
4. Bring your ARC, bankbook, medical report and receipt to OIA, fill out the application form and hand in OIA
5. Attach above documents, copy of ARC and bank book.
6. Insurance Company Review → Transfer compensation directly to applicant's account. (It takes about 2-3 months. Please be patient to wait for it.)



### C. Students' Safety (group) Insurance Program

All NDHU students which include domestic and international students are required to join the "Students' Safety (group) Insurance Program". The insurance premium will be included in your registration fee. For more information, please contact 03-890-6226, borisju@gms.ndhu.edu.tw, Student Living Service Division, Student Affairs.

### D. National Health Insurance (aka. N.H.I.)

**International students who hold a valid ARC over six months, do not leave Taiwan more than once and within 30 days during the six months are eligible, they are required and compulsory to join the NHI program.** International students who enroll into NDHU shall apply for the NHI through OIA when eligible, and the applicable premium is included in the payment sheet since second semester. If you have enrolled in the NHI before your registration with NDHU, please contact OIA and determine whether you will transfer and pay your premium via NDHU; the NHI premium in your payment sheet will be adjusted accordingly.

## National Health Insurance (NHI)

- Students should stay in Taiwan continually for **6 months** and **be allowed to leave Taiwan once (not more than 30 days)**
- Pay attention on your vacation which the longest departure period is within 29 days.

If your ARC is valid from 2022/03/31 假設你的居留證生效日為		
Situation		The time you're qualified to get NHI card
Never leave Taiwan during the first 6 months	Never leave Taiwan	2022/03/31 + 6 months = 2022/09/30
Leave Taiwan once and less than 30 days	08/01~08/20 Leaving Taiwan for 20 days	2022/09/30 + 6 months + 20 days = 2022/10/20
Leave Taiwan once and more than 30 days	8/01~9/10 Leaving Taiwan for 36 days → recalculate	2022/09/10 + 6 months = 2023/03/10
Leave Taiwan twice, but less than 30 days	07/01~07/10 and 08/01~08/05 Leaving Taiwan twice, less than 30 days → recalculate	2022/08/05 + 6 months = 2023/02/05

According to Taiwan regulation: National Health Insurance Act:

<https://law.moj.gov.tw/Eng/LawClass/LawAll.aspx?PCode=L0060001>



Students will get a NHI card after joining the insurance program. OIA will apply IC card for you when you are qualified. As soon as NHI card delivers to OIA office, we will post the notice in Facebook group: NDHU- International Students. Students who is holding NHI card and ARC will be allowed to select medical services from NHI-affiliated hospitals and clinics at a reduced price. Certain registration fees and co-payments may be charged.

Nation Health Insurance Administration, Ministry of Health and Welfare:

<https://www.nhi.gov.tw/English/>

### Difference between insurances @NDHU

Item	Student group insurance	Medical Insurance	National Health Insurance
Who must pay	New/current students	New students who don't have NHI in first 6 months in Taiwan <b>or</b> current students whose ARC is invalid which effects NHI qualification.	Current students who are qualified to join NHI and hold valid ARC
Price	NT\$340/semester	NT\$3000/semester	NT\$4956/semester
Description	The fee of student group insurance is required for all students.  Info: <a href="https://rb005.ndhu.edu.tw/p/405-1005-199363,c8349.php">https://rb005.ndhu.edu.tw/p/405-1005-199363,c8349.php</a>  Latest Notice: <a href="https://rb005.ndhu.edu.tw/p/403-1005-5358.php">https://rb005.ndhu.edu.tw/p/403-1005-5358.php</a>	Medical insurance is required to pay, especially for the students who stay in Taiwan, but not yet quailed to join NHI in first 6 months. With medical insurance, your health and medical problems will be taken care of.  Regulations: please refer to P.27-29.	Regulation refers to P.30
Contact Person	For more questions, please contact Office of Student Affairs #6222	For more questions, please contact ISSA, OIA <a href="mailto:issa@gms.ndhu.edu.tw">issa@gms.ndhu.edu.tw</a>	For more questions, please contact ISSA, OIA <a href="mailto:issa@gms.ndhu.edu.tw">issa@gms.ndhu.edu.tw</a>



### **E. Health Center @NDHU**

Health center is located at Room 114, 1<sup>st</sup> floor, Administration Building.  
Office Hour : Monday to Friday, 08:00-17:00 (No lunch break at noon)  
TEL: 03-890-6254, Email: [chr@gms.ndhu.edu.tw](mailto:chr@gms.ndhu.edu.tw)

### **F. Psychology Counseling Center @NDHU**

Psychological Counseling Center is located on West Community House.  
Office Hour: Monday to Thursday, 08:00-21:00 / Friday, 08:00 to 17:00  
TEL: 03-890-6263

### **G. Student Health Examination**

All new students (Spring/Spring enrollment) are required to have an additional health examination in designated hospital after arrival at NDHU. Health Center will hold the health examination program for all new students on campus. **The fee is around NT\$ 680.** Be advised, all international new students should complete the physical checkup in that year. For further information, please check the announcement of your department **or** Health Center, Office of Student Affairs (03-8906254, [cindy4434@gms.ndhu.edu.tw](mailto:cindy4434@gms.ndhu.edu.tw))

Student Health Examination from Health Center:

<https://rb005.ndhu.edu.tw/p/412-1005-15280.php>

If you are not willing to do the physical checkup on campus, you may also do the health examination in the following hospitals:

#### **Hualien Campus**

##### **Tzu Chi General Hospital**

Location: No.707, Sec. 3, Zhongyang Rd., Hualien City  
Tel: 03-8561825

##### **Mennonite Christian Hospital**

Location: No.44, Minquan Rd., Hualien City  
Tel: 03-8241234

#### **Pingtung Campus**

##### **Antai Tian-Sheng Memorial Hospital**

Location: No.210, Sec. 1, Zhongzheng Rd., Donggang Township, Pingtung County  
Tel: 08-8337771, 08-8332119

##### **Kaohsiung Chang Gung Memorial Hospital**

Location: No.123, Dapi Rd., Niasong Dist., Kaohsiung City  
Tel: 07-7317123

**Kaohsiung Municipal Hsiaokang Hospital**

Location: No.482, Shanming Rd., Siaogang Dist., Kaohsiung City  
Tel: 07-8059152

**Please note you must bring NDHU Student Health Examination Form/ Health Examination Record and your photo ID when reporting to above hospitals.**

# X. NDHU E-mail & Wireless Internet Access

## A. NDHU E-mail Account

All Students are entitled to a free NDHU email account. If there is any campus information, announcements and events, NDHU will send the information to the email account. Your email account consists of your student ID number with a code. The email server for student is **gms.ndhu.edu.tw**

**Note:** Most announcements are in Chinese. The announcements are released by different division. Therefore, OIA suggests students could use Google translate to help you read the email. Here comes the sample:



If there is important news or information related to international students, OIA will translate and post on NDHU-international students FB group.

Link: <https://www.facebook.com/groups/284261925011303>

## B. How to Sign in Personal E-mail Account

Account: Student ID Number **@gms.ndhu.edu.tw**

Password: YYYY.MM.DD (Your birthday)

For example, if your birthday is “1991.01.01”, the password will be “1991.01.01”.

Access your account: <https://www.ndhu.edu.tw/p/412-1000-10949.php?Lang=zh-tw>

Reset password: <http://gms.ndhu.edu.tw/passwd/>

### **C. Wireless Internet Access**

If have a cellphone, laptop and desktop with wireless access function, you can log in NDHU's free wireless network with your own NDHU E-mail account on campus.

**Dormitory area will not provide wireless internet access service, please prepare the patch cable.**

# XI. Course Selection

Online course selection in **2023 Spring Semester**:

For New Students (First Chance) ➤ 02/06 12:30 ~ 02/08 12:30

For All Students (Second Chance) ➤ 02/14 12:30~02/21 12:30

## How to Sign in online course selection?

**Account: Student ID Number**

**Password: Student ID Number +0**

(For example, if your student id is 410112345, your password would be 4101123450.)

Course selection:

<https://sys.ndhu.edu.tw/AA/CLASS/subselect/Default.aspx?lang=en>

Course outline and syllabus: <http://sys.ndhu.edu.tw/aa/class/course/Default.aspx>

Course regulation: <http://sys.ndhu.edu.tw/aa/class/RuleSearch/rulebasic.aspx>

**NOTE:** Please check with your department about course curriculum and credit requirement.

**If you have question about course system, please contact:**

- Course Selection System-Business : Academic Affairs (03)8906122~6126
- System : Library and Information Center (03)8906752~6764

## A. Important Reminders for the Course Registration Process

1. The registration process is divided into an initial phase and a course addition and withdrawal period. The initial registration phase begins at the end of the preceding semester (or **before** the start of the semester for newly enrolled students). The course addition and withdrawal period will be held at a specified time after the official start of the semester. Students have to register for courses within a specified deadline. After the end of the official course registration period, it is impossible to modify course selections.
2. Students who are unable to select certain courses because they are already filled to capacity or due to other factors, can request the instructor's permission to manually sign up for his course within one week after the end of the course addition and withdrawal period provided that the classroom capacity allows it.

Important Reminders for the Course Registration Process:

<https://rb004.ndhu.edu.tw/p/406-1004-107593.php>

## B. Required General Education Course for Undergraduate Students

Regulation for general education course:

<http://sys.ndhu.edu.tw/aa/class/RuleSearch/rulebasic.aspx>



For further General Education Course information, please contact General Education Center, 03-890-6607, mayer@gms.ndhu.edu.tw

## C. Interdisciplinary Autonomous Learning Certified Hours for bachelor degree students

Interdisciplinary Autonomous Learning Certified Hours is charge of Student Activities Division, Office of Student Affairs. Students should finish the required credits before graduation. See more info: <https://rb005.ndhu.edu.tw/p/403-1005-4238.php>

System Link:

[https://sys.ndhu.edu.tw/SA/XSL\\_ApplyRWD/Login.aspx?ReturnUrl=/SA/XSL\\_ApplyRWD/Default.aspx&lang=en](https://sys.ndhu.edu.tw/SA/XSL_ApplyRWD/Login.aspx?ReturnUrl=/SA/XSL_ApplyRWD/Default.aspx&lang=en)

For further Interdisciplinary Autonomous Learning Certified Hours information, please contact Student Activities Division, Office of Student Affairs, (03)890-6228

Guideline by CSIE: <https://www.csie.ndhu.edu.tw/wp-content/uploads/NDHU-Interdisciplinary-Autonomous-Learning-Certification-Implementation-Measures.pdf>

## D. Academic Research Ethics Education Course

Guidelines of Academic Research Ethics Education Course from Curriculum Division, Office of Academic Affairs: <https://aa.ndhu.edu.tw/p/406-1004-94664,r5136.php>

## XII. Open a Bank Account in Taiwan

ATMs will charge NT\$ 300~400 for processing fees and currency exchange difference if a foreign bank card is used.

### A. Chunghwa Post Company (aka. Post Office)

Post office in Taiwan provides both postal and banking services, including shipping, receiving, deposit and withdrawal...etc.

To open a financial account in the post office, you should prepare:

1. Get the application form from post office
2. Original and one copy of passport and ARC IC card (e-ARC should be printed out.)
3. **Student Status Certificate**
4. *Personal Seal*

#### Post Office - Shoufeng Dong Hwa University

Location: 1F, Administration Building

Office hour: Weekdays 09:00-17:00 (break time: 13:00-13:30)

Phone: 03-863-0169

Google Map: <https://goo.gl/maps/xHG2eEWSpDM5cMB39>

Chunghwa Post Company: [https://www.post.gov.tw/post/internet/U\\_english/](https://www.post.gov.tw/post/internet/U_english/)

### B. Taiwan Business Bank: On-Campus & ATM

You can only apply for a bank account, ATM card and money exchange from Taiwan Business Bank **in Hualien city**. ATM can be found at post office, Taiwan Business Bank and convenience stores on- and off-campus. You must be **over the age of twenty to apply**.

To open a financial account in Taiwan Business Bank, you should prepare:

1. Get the application form from bank
2. Original and one copy of passport and ARC IC card (e-ARC should be printed out.)
3. **Student Status Certificate**

#### Shoufeng Campus

Location: 1F, Administration Building

Office hour: 10:00-12:00

Phone: 03-863-0135

#### Hualien City

Location: No.247, Zhongshan Rd., Hualien City,  
Hualien County 970, Taiwan (R.O.C.)

Office hour: 09:00-15:30

Phone: 03-835-7171

Taiwan Business Bank: <https://www.tbb.com.tw/web/guest/english2>

## XIII. Work Permit

International students who would like to work as part-timer in Taiwan which is either on the campus or off campus are **required to apply and obtain a work permit before starting to work**. Please note if you hold a job without applying for a work permit, you may be fined for NT\$30,000~ NT\$150,000. If you get reported without the work permit, student status will be canceled, even DEPORTATION. Online application takes 5-10 weekdays.

**Workforce Development Agency (WDA) EZ Work Permit Online Application System:**

<https://ezwp.wda.gov.tw/wcfonline/wSite/Control?function=IndexPage>

**Instruction manual:**

<https://ezwp.wda.gov.tw/wcfonline/wSite/download/student.pdf>

**Video:**

<https://www.youtube.com/watch?v=NB4yjKOK3Yg&list=PLXxGiQC4GemsIZBeIn7M5c5kQ2a1g2CKY&index=26>

### A. Required Documents

1. Create an account in EZ work permit system
2. PDF of Student ID card and **Student Status Certificate** (registered semester)

*Download the student status certificate on e-Portfolio system:*

[https://sys.ndhu.edu.tw/CTE/Ed\\_StudP\\_WebSite/Login.aspx](https://sys.ndhu.edu.tw/CTE/Ed_StudP_WebSite/Login.aspx)

3. PDF of ARC on front and back side (Note: make sure the valid date!)
4. PDF of passport with photo
5. NT\$ 100

*Make the payment of NT\$ 100 with the postal remittance which you can take it from OIA **or** post office. After the payment, keep the receipt and enter the receipt number into EZ work permit system.*

98-04-43-04 郵政劃撥儲金存款單		◎寄款人請注意背面說明 ◎本收據由電腦印錄請勿填寫	
收 款 帳 號	19058848	金額 (阿拉伯數字)	壹 仟 萬 零 拾 元
通訊欄 (限與本次存款有關事項)		收款 戶名	勞動部勞動力發展署聘僱許可收費專戶
		寄 款 人	<input type="checkbox"/> 他人存款 <input type="checkbox"/> 本戶存款
		姓 名	name
		地 址	97401花蓮縣壽豐鄉大學路2段1號
		電 話	phone number
		主管:	
		經辦局收款章戳	
		電腦紀錄	
		經辦局收款章戳	





For Example:

Post office remittance: 009139

Receipt number (the last 7 numbers): 0000315

Remittance date (type the 6 numbers): 1071016

## B. Notes

1. The status of international students in Taiwan should be in accordance with the regulations of the Ministry of Education.
2. A work permit is valid for six months at most. For applications made in the first semester (Spring semester), the work permit is **valid until March 31 of the following semester**; for applications made in the second semester (spring semester), the work permit is **valid until September 30 of the same year**.

## C. Here come the common cases that you will be rejected

### 1) Your work permit duration is over your passport or ARC expiry date...

ANS: Please correct the work permit application time date as same as your passport or ARC expiry date.

### 2) When you are uploading old passport...

ANS: Please upload both of old and new passport.

### 3) No valid student status certificate in registered semester....

ANS: Please upload the valid student status certificate on e-Portfolio system: [https://sys.ndhu.edu.tw/CTE/Ed\\_StudP\\_WebSite/Login.aspx](https://sys.ndhu.edu.tw/CTE/Ed_StudP_WebSite/Login.aspx)

### 4) Typing wrong payment receipt number...

ANS: Correct the receipt number and upload your payment receipt

## XIV. Academic Integrity & Plagiarism

It is your responsibility to be aware of University regulations. At NDHU, penalties for plagiarism and other academic misconduct range from a failing grade in the course to suspension from the University.

One of the most serious academic offences is plagiarism (submitting the work of another person as your own). Some students have reported striking differences between the concept of intellectual property in their cultures and in Taiwan. Intellectual property includes ideas, arguments, phrases, sentences, paragraphs, or results of research (including material found on the web). Using someone else's work without acknowledgment is not considered a way of honoring that person, even if the work is commonly known.

When you use excerpts from someone else's work in your essay, paper, or presentation, you must acknowledge the original author in a footnote or another accepted manner. You may not copy all or any part of another person's work, and you may not purchase a paper from anyone (or from websites) and present it as your own.

## XV. NDHU Complaint Processing Rules

If any student, student body or other relevant student self-governing organization (hereinafter the “Complainant”) believes that any disciplinary sanctions, other measures or resolutions are illegal or inappropriate, causing damage to its right or interest, a complaint may be filed with the School in accordance with rules related to student complaint of the School.

Student referred to in the previous paragraph means a student registered with the School when the disciplinary sanctions, other measures or resolutions are imposed. Student could directly submit the complaint cases in the following system from Student Living Service Division, Office of Student Affairs.

National Dong Hwa University Student Appealing Measure:

<https://rb005.ndhu.edu.tw/p/404-1005-8198.php>

NDHU i-communication: <https://web.ndhu.edu.tw/SCR/pprz/PPRZList.aspx>

## XVI. Scholarship

Please check OIA website for latest information and application procedure:

<https://oia.ndhu.edu.tw/intl-student/intl-scholarship>

### A. Application Eligibility

National Dong Hwa University International Student Scholarship Regulations:

<https://oia.ndhu.edu.tw/intl-student/intl-scholarship/intl-scholarship-information>

#### Article 4

1. Newly admitted students: Newly admitted International Students who followed the proper application procedures for International Students and are officially enrolled at NDHU. Scholarships will be awarded to students with outstanding performances after a review of their application documents and academic achievements.
2. Currently enrolled students:
  - (1) Students who have been enrolled for at least one semester of full-time study, have successfully completed their courses, and have no record of serious infractions (reprimand, minor demerit, major demerit, detention or expulsion from school)
  - (2) Students who are working on their PhD or Master's thesis and have not signed up for any courses in the precious semester can submit their thesis proposal along with their application during the application period. The thesis proposal should contain the research motivation and objectives, the research structure and design, the data sources and collection methods, the thesis outline, and a bibliography.
3. Recipients of scholarships from the Taiwanese government or other Taiwanese government related agencies are not eligible to apply.
4. Students should have no record of infractions more serious than reprimands.

### B. Quota and Type

#### Article 5

1. Approved quota: The quota of scholarship recipients is determined based on available budgets.

## 2. Scholarship types:

- (1) Tuition scholarship: partly or up to full tuition waiver for the semester (reduction of basic tuition fees and miscellaneous fees).
- (2) Stipend scholarship: NTD \$20,000 ~ \$30,000 for the semester.
- (3) Accommodation scholarship: full accommodation waiver for the Semester (exemption from dormitory fees and basic utilities fees, and this does not cover summer, winter dormitory and basic utilities fees).

### Notes:

- (1) Tuition and miscellaneous fees are charged according to the latest university announcements.
- (2) Tuitions and miscellaneous fees do not include other related expenses such as proxy fees, insurance charges, and Internet usage fees.
- (3) Outstanding students can be awarded more than one scholarship.

## **C. Awarded Students Must Comply with The Regulations & Duties**

### *Article 8*

1. Registration procedures must be completed no later than the deadline officially announced by NDHU.
2. Awarded students of the Scholarship must not apply for related concessions the following semester once failing to meet the requirements stated in Article 4.
3. If a student is expelled from school, the student loses eligibility, and scholarship payment will cease the month following the student's departure.
4. If a student takes a leave of absence from school, scholarship payments will cease the month following the student's departure. When student resumes the study, he or she may apply scholarships before the application deadline of that semester.
5. Newly admitted students awarded the Scholarship must not apply for admission reservation unless with special incidents and approved by the International Student Admission Committee.
6. Where one of the following conditions applies, the University may request that scholarship recipients complete a Mandarin course in the respective semester to stimulate interactions with local faculty members and students

- (a) Students are enrolled in programs taught in Mandarin and don't hold TOCFL Level 3 or equivalent proficiency certificates.
- (b) Students are enrolled in programs taught in English and have not successfully completed two Mandarin courses or don't hold TOCFL Level 1 or equivalent proficiency certificates.

Where students fail to meet the aforementioned requirements, scholarship contents may be adjusted by review units as deemed appropriate.

The government of Taiwan, R.O.C. and National Dong Hwa University (NDHU) provide various scholarships to foreign students. Each scholarship has specific regulations. We assume that each applicant has read the regulations carefully before submitting the application materials to the related offices. To review the regulations, please visit the following websites for more details.

Reminder: please hold an alien resident certificate for the study within the enrollment semesters at NDHU if you are one of the recipients with the scholarship provided by the government. It will be canceled the scholarship if the recipient with an alien resident certificate for the work, a family relationship or APRC holders.

### **Scholarship regulations**

- Taiwan Scholarship <https://tafs.mofa.gov.tw/Schs.aspx?loc=en>
- MOE Scholarship <https://tafs.mofa.gov.tw/SchDetailed.aspx?loc=en&ItemId=18>
- MOFA Taiwan Scholarship  
<https://tafs.mofa.gov.tw/SchDetailed.aspx?loc=en&ItemId=15>
- NDHU Southern Scholarship <https://oia.ndhu.edu.tw/intl-student/intl-scholarship/southward-scholarship>
- NDHU Scholarship <https://oia.ndhu.edu.tw/intl-student/intl-scholarship/intl-scholarship-information>

### **【 The regulations regarding installment application for scholarship recipients 】**

#### **New incoming students with Taiwan Scholarship, Elite scholarship, or BPLIN scholarship**

It is allowed to apply for deferred payment of the registration fee for the first semester until 30<sup>th</sup> October (only for the students enrolled in the Spring semester) or 15<sup>th</sup> April (only for the students enrolled in the spring semester). Because most recipients do not

have a bank account in Taiwan, it is difficult to withdraw or deposit money supported by family members. Considering that it takes at least one month to create a new bank account in Taiwan, the recipient of the MOFA, MOE or MOST Taiwan scholarships, and Elite Southern Scholarship as well as BPLIN scholarship can apply for a deferred payment from the school if needed. Please consult the departmental office regarding this process.

### **New incoming students with NDHU Southern Scholarship or NDHU Scholarship**

It is **NOT allowed** to apply for an installment or deferred payment from the school because of the waiver of basic tuition and credit hours' fees in the first semester. Please check the payment slip using the payment online system for information about how much money you should prepare.

After the recipient completes the registration process, and receives a bank account in Taiwan, they will receive a stipend of 2-3 months at the first time because of creating a new bank account in Taiwan. Please prepare enough money to stay in Taiwan. Subsequently, the stipend is issued every month until the current semester ends.

The duration of the NDHU scholarship is one semester. It is allowed to apply for the installment in the subsequent semesters. Please plan your finances accordingly to ensure a smooth study life in NDHU.

### **The issued time for the scholarships**

The stipend is issued only for students who complete the registration process. New incoming students without an Alien Residential Card (ARC) and bank account in Taiwan may experience initial delays in the scholarship process. Usually recipients receive the first stipend (or scholarship) at the end of October or at the end of November (only for the students enrolled in the Spring semester); students who enrolled in the spring semester will usually receive it at the end of March or at the end of April.

All scholarship recipients should complete the registration process scheduled by the school in order to receive the stipend and other scholarship payments. Failure to complete the required process in time will lead to delays. Students who do not complete the registration process in time will be assumed to have cancelled their enrollment. Based on the regulations of all scholarships, stipends are not issued until the registration process has been completed.

The assistant of the Office of International Affairs processes the administration proceeding around the 15<sup>th</sup> or 16<sup>th</sup> of each month. Usually, it will take 5-10 working days to review and process the deposit proceedings by the related offices at NDHU.

Recipients usually receive the stipend around the end of the month. We strongly suggest making a good financial planning.

The payment slip online system (registration and dormitory fees)

<https://school.bot.com.tw/newTwbank/StudentLogin.aspx>

Registration online system <https://sys.ndhu.edu.tw/AA/REG/register/>

### **New incoming students with an Alien Residential Card (ARC) and a bank account in Taiwan**

**The stipend will be issued only after the applicant submits the relevant banking information in the registration online system.** This online system is opened only during specific periods. Outside of the system's operational periods, please use the e-Portfolio online system to submit the banking information.

Registration online system <https://sys.ndhu.edu.tw/AA/REG/register/>

e-Portfolio online system

[https://sys.ndhu.edu.tw/CTE/Ed\\_StudP\\_WebSite/Login.aspx](https://sys.ndhu.edu.tw/CTE/Ed_StudP_WebSite/Login.aspx)

### **New incoming students without an alien residential card (ARC) or a bank account in Taiwan**

Applicants should create a bank account in Taiwan as soon as possible after receiving an alien residential card (ARC). Please log into the registration online system to submit the banking information. This online system is opened only during specific periods. Outside of the system's operational periods, please use the e-Portfolio online system to submit the banking information.

Registration online system <https://sys.ndhu.edu.tw/AA/REG/register/>

e-Portfolio online system

[https://sys.ndhu.edu.tw/CTE/Ed\\_StudP\\_WebSite/Login.aspx](https://sys.ndhu.edu.tw/CTE/Ed_StudP_WebSite/Login.aspx)

If a new incoming student creates a bank account and submit it using the online system at the end of April successfully, we assume that the issued time for the scholarships



will be at the end of May or at the beginning of June. Thus, we kindly remind you to make a good financial planning.

**If you have any questions about scholarship, please contact Admission Division [admission@gms.ndhu.edu.tw](mailto:admission@gms.ndhu.edu.tw)**

#### **D. TOCFL Placement Test**

Chinese language course is free. TOCFL Placement Test is used as a reference for students who will take the Chinese language courses and it is not mandatory to participate. If have never learned Chinese, students can choose the Fundamental Chinese Course directly. Students who take the placement test, Chinese Language Center will e-mail the result and suggested level of Chinese language course to you. Please complete the test before Sep. 1<sup>st</sup>.

More information please contact 03-890-5238, [clcndhu@gms.ndhu.edu.tw](mailto:clcndhu@gms.ndhu.edu.tw).

TOCFL Placement Test:

<https://docs.google.com/forms/d/e/1FAIpQLScZ70oL7n2vHpp9DZfKXOpcvrpHjDNUjvF3hiT0ID13VLzu4A/viewform>

## XVII. International Student Identity Card

For the International Student Identity Card (ISIC), please directly apply from Kang Wen Culture & Education Foundation which is the exclusive representative in Taiwan. Registry Division, Office of Academic Affairs will not provide the ISIC anymore. Check out the domestic and international discounts from the webpage: <https://www.isic.com.tw/home/en/index.html>

### Required Documents

1. Online application form
2. Recent passport size photo to your closest STA Travel branch, or ready for upload when you apply online.
3. Student ID card and Student Status Certificate
4. Official proof of your date of birth (ie. passport, driver license, birth certificate or ARC)
5. NT\$ 400



# XVIII. NDHU Campus Map

## 國立東華大學校園導覽平面圖



NDHU campus map: <https://www.ndhu.edu.tw/p/405-1000-47512,c9371.php?Lang=zh-tw>

Vehicle Permit Application: <https://web.ndhu.edu.tw/GA/TSVMS/VPass/Login.aspx>

Campus Parking and riding info: <https://ga.ndhu.edu.tw/p/412-1006-18901.php?Lang=zh-tw>

Campus Entrance instruction: <https://ga.ndhu.edu.tw/p/412-1006-18902.php?Lang=zh-tw>

Buses Info and real time bus stop departure: <https://ga.ndhu.edu.tw/p/405-1006-150910,c17163.php?Lang=zh-tw>

Bicycles garage sale: <https://ga.ndhu.edu.tw/p/412-1006-19115.php?Lang=zh-tw>